

# 3D PRINTER TABLE

3DP-3624 (OAK OR MAPLE)  
ASSEMBLY INSTRUCTIONS

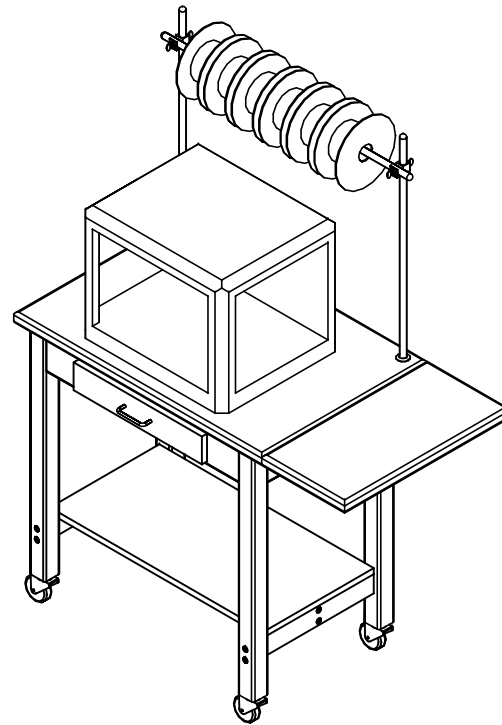

**NOTE:**

1. MODEL VIEWS MAY NOT REPRESENT EXACT MODEL PURCHASED

DWN BY:	EMK	DWN DATE:	10/26/17
APR BY:		DATE APR:	
APR BY:		DATE APR:	

UNLESS OTHERWISE SPECIFIED  
DIMENSION ARE IN INCHES  
CABINET SQUARENESS ± .0625  
FRACTIONAL VALUES ± 1/32"  
- ALL VALUES ± OVERALL -



300 South Krueger Street  
Suring, WI 54174  
diversifiedwoodcrafts.com

TITLE:  
3D PRINTER TABLE  
ASSEMBLY INSTRUCTIONS

A	CREATED DRAWING	10/26/17	EMK	-
REV.	DESCRIPTION	DATE	NAME	ECN NO.

REVISION LEVEL

THIS DRAWING IS THE SOLE PROPERTY OF  
DIVERSIFIED WOOD CRAFTS. IT MAY NOT  
BE ALTERED OR CHANGED WITHOUT  
PERMISSION

DRAWING NUMBER:

3DP-3624

SCALE:

NTS

SHEET:

1 OF 5

REVISION:

REV A

## TOOLS REQUIRED

1/2" WRENCH
1/2" SOCKET AND TORQUE WRENCH - OPTIONAL
4MM ALLEN WRENCH
SCREW DRIVER

## ASSEMBLY COMPONENTS

ITEMS INCLUDED	PART #	PART DESCRIPTION	QTY
TOP AND APRON ASSEMBLY	N/A	TOP ASSEMBLY (FACTORY ASSEMBLED)	1
LEGS WITH CASTERS	501103	LEG,MPL 2.25X2.25X32.25	4
STRETCHER	N/A	STRETCHER - 0.75"THK X 2.50"W X 29.50"L	1
LEG BRACE	N/A	LEG BRACE - 0.75"THK X 2.50"W X 16"L	2
SHELF	N/A	SHELF - 0.75"THK X 15.875"W X 31.125"L	1
CONFIRMATS - LEGS	227578	SCREW,7MMX90MM,CONN,ALLENHEAD, BLACK	8
CONFIRMATS - STRETCHER	228564	SCREW,7MMX50MM,CONN,ALLENHEAD, BLACK	4
SCREWS - SHELF	100066	SCREW,#8X1.5 FSQ SMS TYPE 17	4
ROD SOCKET	206505	ROD SOCKET ASSY,SOCKET,WASHER,NUT	2
CROSSBAR	100094	ROD,CROSSBAR 3/4 DIA.X36 L	2
UPRIGHT	100004	ROD,UPRIGHT 3/4 DIA.X36 L	2
CLAMP	253011	ROD CLAMP 3/4X3/4 ASSY, NOTCHED FOR LIFT OUT BAR	2

**NOTE:**

1.

DWN BY:	EMK	DWN DATE:	10/26/17
APR BY:		DATE APR:	
APR BY:		DATE APR:	

UNLESS OTHERWISE SPECIFIED  
DIMENSION ARE IN INCHES  
CABINET SQUARENESS ± .0625  
FRACTIONAL VALUES ± 1/32"  
- ALL VALUES ± OVERALL -



300 South Krueger Street  
Suring, WI 54174  
diversifiedwoodcrafts.com

TITLE:  
3D PRINTER TABLE  
TOOLS AND ASSEMBLY COMPONENTS

A	CREATED DRAWING	10/26/17	EMK	-
REV.	DESCRIPTION	DATE	NAME	ECN NO.

REVISION LEVEL

THIS DRAWING IS THE SOLE PROPERTY OF  
DIVERSIFIED WOOD CRAFTS. IT MAY NOT  
BE ALTERED OR CHANGED WITHOUT  
PERMISSION

DRAWING NUMBER:

3DP-3624

SCALE:	SHEET:	REVISION:
NTS	2 OF 5	REV A

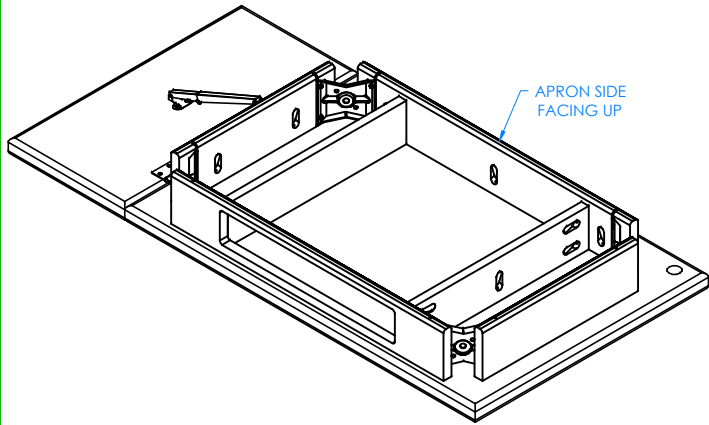

STEP 1:  
LAY TOP ASSEMBLY ON FLOOR WITH APRON SIDE FACING UP. BE SURE TOP ASSEMBLY IS ON A CLEAN SURFACE TO PREVENT DAMAGE.

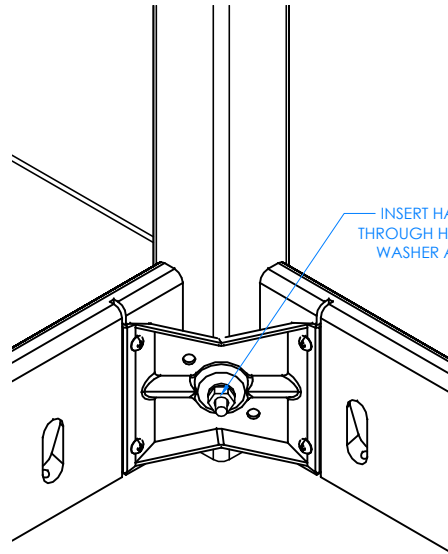

CLOSE UP OF CORNER LEG ASSEMBLY  
(INTERNALS REMOVED TO SHOW CLARITY)

STEP 2:  
INSERT HANGER BOLT THROUGH CORNER BRACKET AND INSERT LOCK WASHER AND HEX NUT. USING A 1/2" WRENCH OR 1/2" SOCKET AND TORQUE WRENCH, SCREW ON THE NUT BUT DO NOT TIGHTEN ALL THE WAY. REPEAT FOR THE OTHER LEGS.

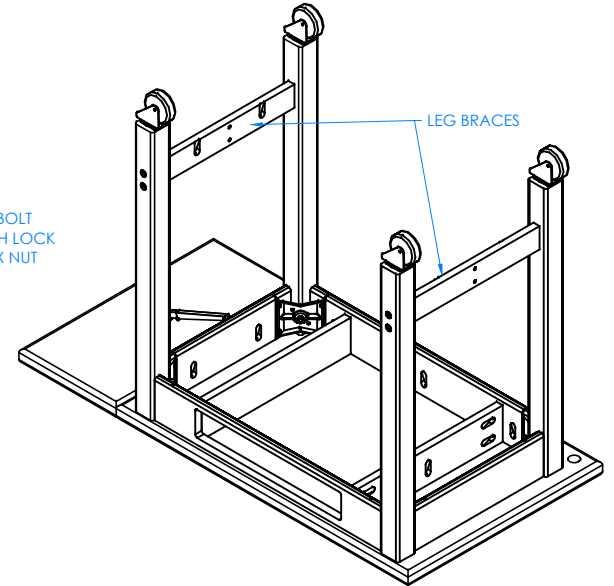

STEP 3:  
USING A 4MM ALLEN WRENCH, INSERT THE CONFIRMATS INTO ONE OF THE LEGS AND SCREW INTO THE BRACE. REPEAT FOR THE OTHER LEGS. MAKE SURE BRACES ARE STRAIGHT AND ALL CONFIRMATS ARE TIGHT.

NOTE:

- 1.

DWN BY:	EMK	DWN DATE:	10/26/17
APR BY:		DATE APR:	
APR BY:		DATE APR:	

UNLESS OTHERWISE SPECIFIED  
DIMENSION ARE IN INCHES  
CABINET SQUARENESS ± .0625  
FRACTIONAL VALUES ± 1/32"  
- ALL VALUES ± OVERALL -



300 South Krueger Street  
Suring, WI 54174  
diversifiedwoodcrafts.com

TITLE:  
3D PRINTER TABLE  
ASSEMBLY INSTRUCTIONS

REV.	DESCRIPTION	DATE	NAME	ECN NO.
A	CREATED DRAWING	10/26/17	EMK	-
REVISION LEVEL				

THIS DRAWING IS THE SOLE PROPERTY OF  
DIVERSIFIED WOOD CRAFTS. IT MAY NOT  
BE ALTERED OR CHANGED WITHOUT  
PERMISSION

DRAWING NUMBER:  
3DP-3624

SCALE:	SHEET:	REVISION:
NTS	3 OF 5	REV A

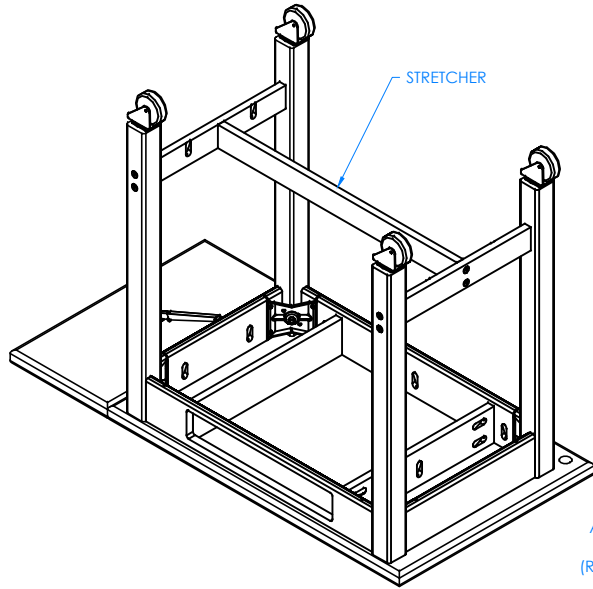

STEP 4:  
 INSERT STRETCHER ONCE LEG BRACES ARE IN POSITION. ATTACH STRETCHER WITH THE CONFIRMATS PROVIDED. GO BACK TO STEP 2 AND TIGHTEN UP THE HANGER BOLTS FOR EACH LEG USING A 1/2" WRENCH OR 1/2" SOCKET AND TORQUE WRENCH, TO A MINIMUM OF 12FT LBS BUT NOT TO EXCEED 17FT LBS.

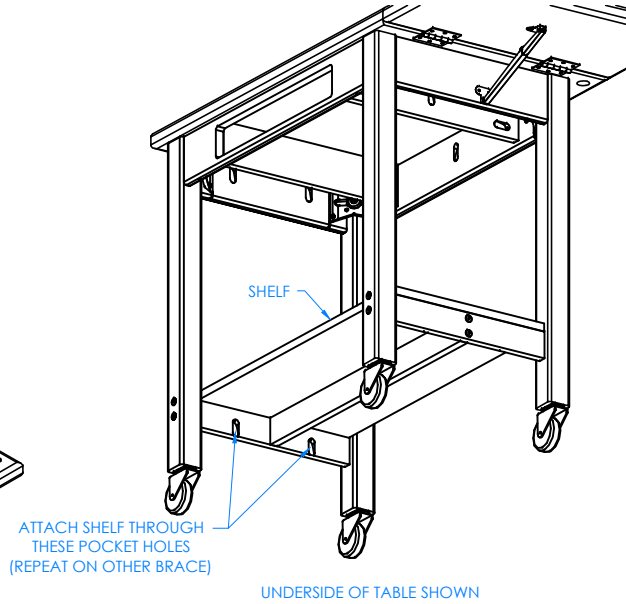

ATTACH SHELF THROUGH THESE POCKET HOLES (REPEAT ON OTHER BRACE)  
 UNDERSIDE OF TABLE SHOWN

STEP 5:  
 TURN TABLE OVER SO TOP IS UP. ATTACH THE SHELF TO THE TOP OF STRETCHER AND LEG BRACES BY GOING UNDERNEATH THE TABLE AND INSERTING THE SCREWS PROVIDED INTO THE POCKET HOLES IN EACH BRACE.

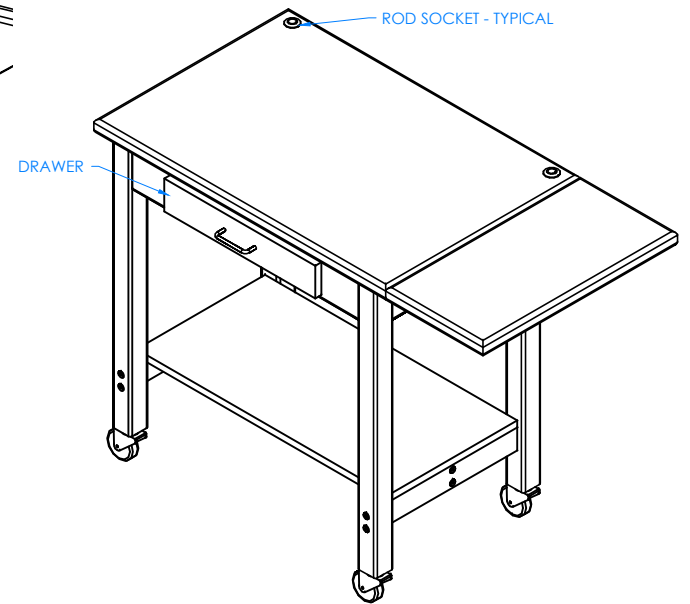

STEP 6:  
 PLACE DRAWER INTO TABLE. INSERT ROD SOCKETS INTO PRE-DRILLED HOLES ON TOP.

NOTE:

- 1.

DWN BY:	EMK	DWN DATE:	10/26/17
APR BY:		DATE APR:	
BY:		DATE APR:	

UNLESS OTHERWISE SPECIFIED DIMENSION ARE IN INCHES  
 CABINET SQUARENESS ± .0625  
 FRACTIONAL VALUES ± 1/32"  
 - ALL VALUES ± OVERALL -



300 South Krueger Street  
 Suring, WI 54174  
 diversifiedwoodcrafts.com

TITLE:  
 3D PRINTER TABLE  
 ASSEMBLY INSTRUCTIONS

REV.	DESCRIPTION	DATE	NAME	ECH NO.
A	CREATED DRAWING	10/26/17	EMK	-
REVISION LEVEL				

THIS DRAWING IS THE SOLE PROPERTY OF DIVERSIFIED WOOD CRAFTS, IT MAY NOT BE ALTERED OR CHANGED WITHOUT PERMISSION

DRAWING NUMBER:  
 3DP-3624

SCALE:	SHEET:	REVISION:
NTS	4 OF 5	REV A

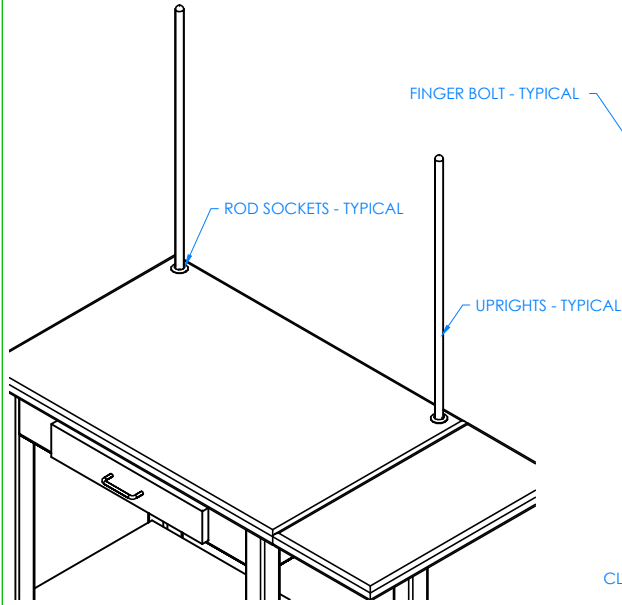

STEP 7:

INSERT TAPERED END OF THE UPRIGHT INTO THE ROD SOCKETS ON THE TOP.

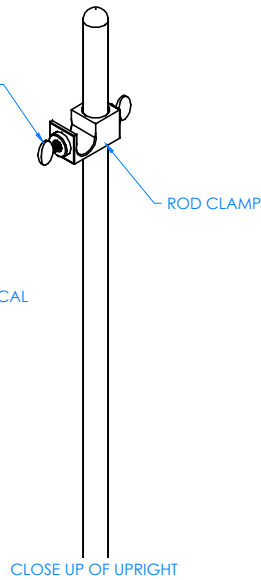

STEP 8:

SLIDE ROD CLAMP OVER ONE OF THE UPRIGHTS AND TIGHTEN IN DESIRED LOCATION USING THE FINGER BOLTS PROVIDED ON CLAMPS. REPEAT ON OTHER UPRIGHT.

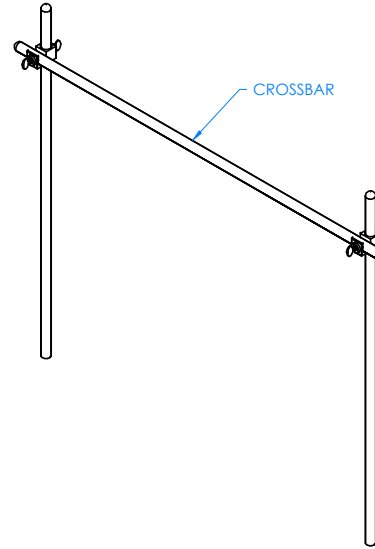

STEP 9:

PLACE CROSS BAR ON GROOVE LOCATED ON CLAMPS. SOME ROD CLAMP ADJUSTMENTS MAY BE REQUIRED.

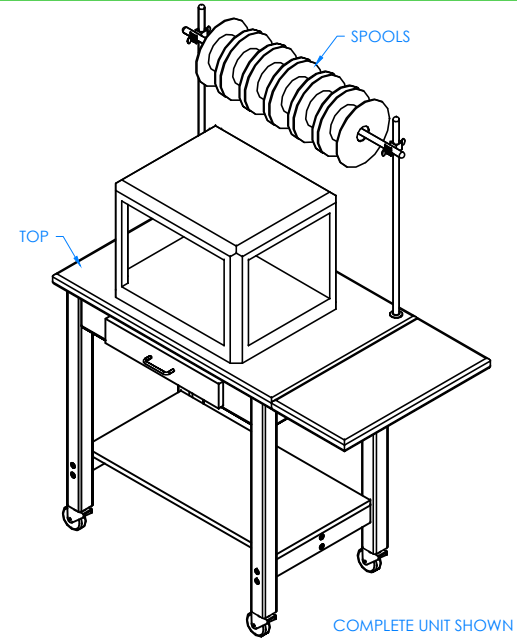

STEP 10:

SET TABLE IN DESIRED LOCATION, PLACE 3D PRINTER ON TOP. SLIDE SPOOLS ON CROSS BAR BY REMOVING CROSSBAR AND ADDING SPOOLS AS DESIRED.

NOTE:

- 1.

DWN BY:	EMK	DWN DATE:	10/26/17
APR BY:		DATE APR:	
APR BY:		DATE APR:	



300 South Krueger Street  
Suring, WI 54174  
diversifiedwoodcrafts.com

UNLESS OTHERWISE SPECIFIED  
DIMENSION ARE IN INCHES  
CABINET SQUARENESS ± .0625  
FRACTIONAL VALUES ± 1/32"  
- ALL VALUES ± OVERALL -

THIS DRAWING IS THE SOLE PROPERTY OF  
DIVERSIFIED WOOD CRAFTS. IT MAY NOT  
BE ALTERED OR CHANGED WITHOUT  
PERMISSION

TITLE:  
**3D PRINTER TABLE  
ASSEMBLY INSTRUCTIONS**

REV.	DESCRIPTION	DATE	NAME	ECN NO.
A	CREATED DRAWING	10/26/17	EMK	-
REVISION LEVEL				

DRAWING NUMBER:

**3DP-3624**

SCALE:	SHEET:	REVISION:
NTS	5 OF 5	REV A