

MB4836WW

Double-Sided Magnetic Whiteboard

Product Specifications

Item Number	MB4836WW
Material	Painted Steel
Frame	Aluminum; 1" edging
Surface Material	Magnetic Painted Steel
Full Dimensions	51.5"W x 20.5"D x 65.5"H
Board Dimensions	48"W x 36"H
Base Dimensions	51.5"W x 20.5"D
Tray Dimensions	47" W x 3" D
Casters (4)	2" casters; two with locking brakes
Actual Weight	35 lbs.
Shipping Method	Freight
Shipping Carton Dimensions	54"W x 45"D x 2"H
Shipping Weight	40 lbs.
Assembly Required	Yes

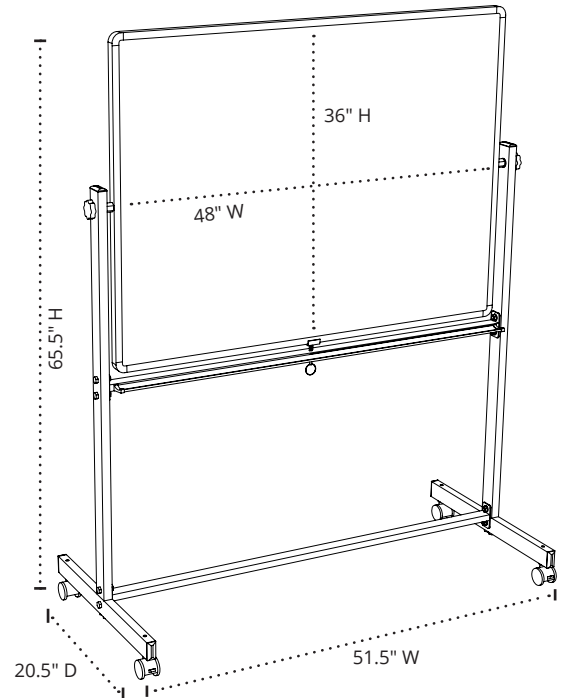

To Order, Call Your
Sales Representative
or 800-323-4656